



# EXPANSION JOINT



UnisonHKR has more than 45 years of track record in design engineering expertise & production know-how marked with numerous acclaim & recognition as a global leading Expansion Joint manufacturer.



DNV·GL



[www.unisonhkr.com](http://www.unisonhkr.com)

# Metallic Expansion Joint



## Features

- Installed in piping/ducting to absorb expansion and contraction caused by temperature & pressure changes
- Bellows with one or multiple plies of Stainless steel, Carbon steel, Incoloy, or Inconel
- Formed by hydro forming, Roll forming or Press forming
- Wild range of products- Universal Hinge, Gimbal, Pressure balance, Rectangular type and more

## Application

- Power Generation (Fossil Fuel/Gas Turbine/Co-gen/Nuclear)
- Refineries & Petroleum Industry
- Chemical Plant
- Steel Mills & Cement Plant
- Marine (on-shore / off-shore)
- Environmental Plant



Universal Type



Hinged Type



Gimbal Type



Pressure Balanced Type



Rectangular Type



Free Type

# Non-Metallic Expansion Joint

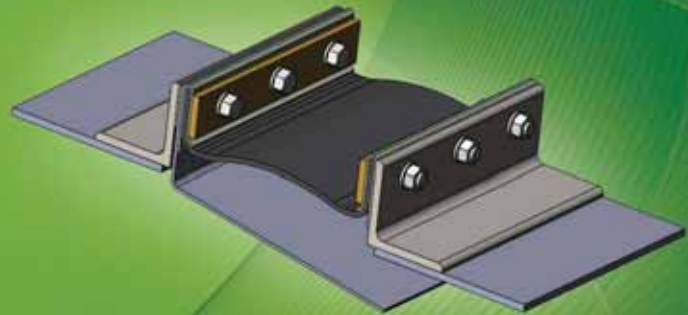

Flange Type

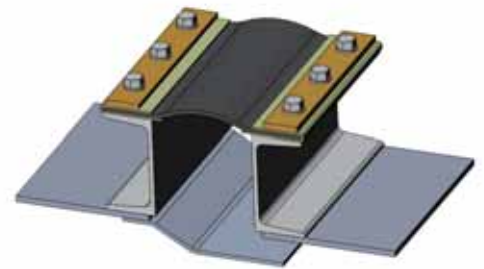
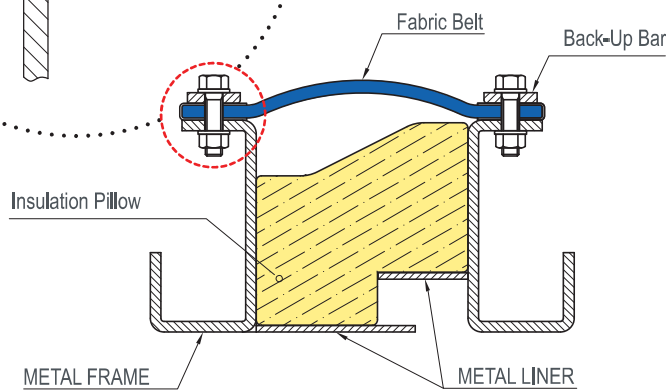
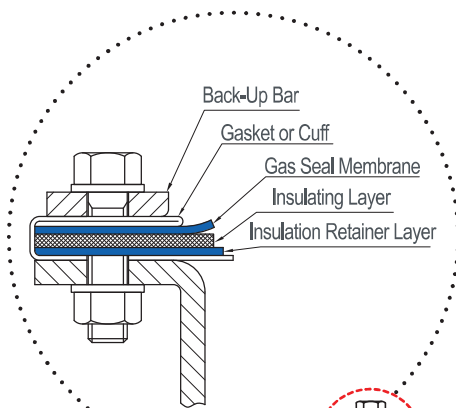

Belt Type



Casing Type

## Features

- Wide variety of non-metallic materials, including synthetic elastomers, fabrics, insulation materials and fluoroplastic, depending on the design.
- Superior corrosion resistance at various temperature
- Minimal field assembly requirements and low maintenance costs
- Capable in any sizes in dimension
- Temperature: up to 1200deg.C

## Application

- Power Generations (Fossil Fuel/Gas Turbine/Co-gen/Nuclear/Biomass)
- Refineries & Petro-Chemical Industry
- Various Industrial Plants
- Environment Plants



# Crossover Pipe & BFPT Duct (Large Bore Pipe)

## Features

- Suitable flexibility to work in different thermal movement condition between turbine and casing
- Supports major global steam turbine manufacturers such as GE, MHPs, Toshiba, Siemens and Doosan
- Expansion Joint : Pressure balance type
- Wide range of product : for 2 nozzles, 3 nozzles, 4 nozzles and BFPT duct

## Application

- Steam turbines for Power plant
- Boiler feed water pump turbines



Crossover



BFPT Duct

# Cryogenic Bellows for LNG Carriers & Terminals



## Features

- Expansion joints from 32 up to 1465mm diameter that can withstand cryogenic temperature/environment
- Expansion joints for LNG carriers are inspected by Lloyd's Register, ABS, DNV, BV, KR, NK and GTT
- Available Materials : 316L Stainless Steel, Incoloy 825, Invar

## Test & Inspection

- Non-Destructive Examination (Radiographic Test/Penetration Test)
- Squirm & Burst Test   ▪ Fatigue cycle Test   ▪ Cryogenic Test



Pressure Cycle Test



Installation on the ship



Operation field test



# Rubber Expansion Joint



## Features

- Fabricated from natural or synthetic elastomers and fabrics with metallic reinforcements designed to provide stress relief in piping systems
- Various rubber materials applicable :  
EPDM, Hypalon, Neoprene, Viton and Natural Rubber
- Spool type(Single/Multiple arch, Reducer, Filled arch) and Dog-bone type

## Application

- Hydraulic Pipes, Heating Installation and Piping in power stations and in the chemical industry

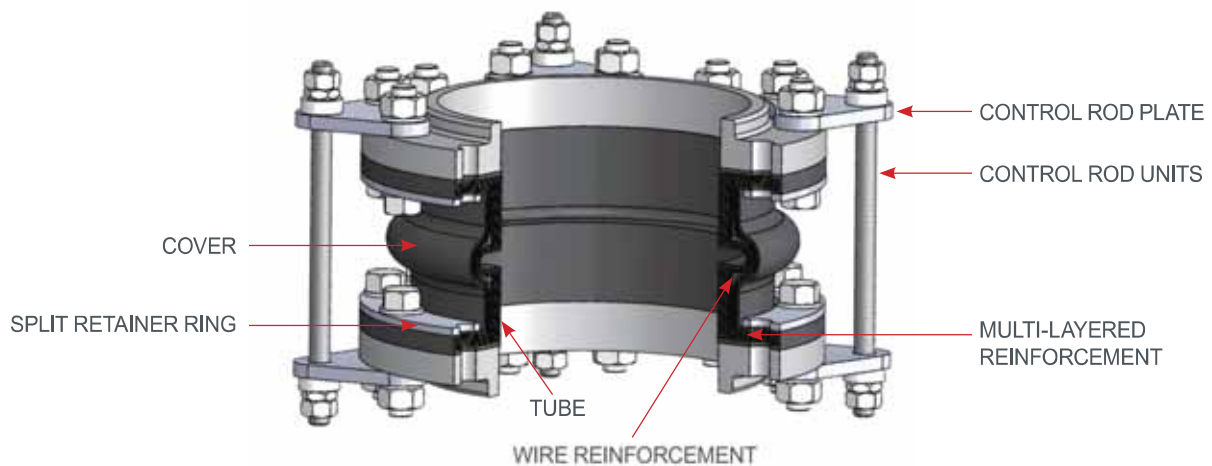
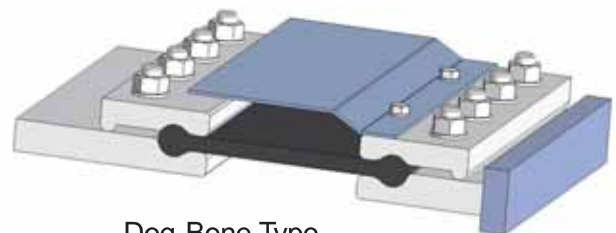

# Flexible Hose

## Features

- Enhancing flex resistance and flexibility
- Variety of End Fittings : Union, Flange, Nipple, Socket, Quick coupling and etc.

## Application

- Hydraulic Pipes, Heating Installation and Piping in power stations and in the chemical industry



# Heat Exchanger Bellows

## Features

- Installed on the shell of the heat exchanger, and restrain heat stress generated by temperature difference between shell and tube.
- ASME "U / U2" Stamp is required

## Application

- Heat Exchanger



## Major Customers

### Domestic



### Overseas



### End-User

